

## INSTALLATION INSTRUCTION for Integral Tough Shell Agriculture LED battens 3 Year Warranty

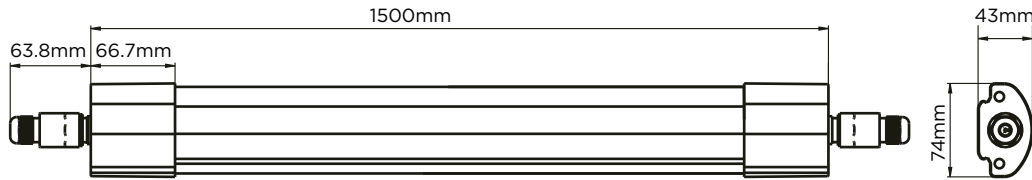

Product code	Function	CCT	Net weight (Kg)
ILBTG090	5ft 43W LED Batten	4000K	1.14

**Thank you for purchasing an INTEGRAL LED product. When installed correctly this unit will provide years of service - with no lamp changes required. For support or warranty information please see [integral-led.com](http://integral-led.com). Always turn off circuit power at the distribution unit before installation and maintenance. Please ensure that the power cannot be connected inadvertently.**

### Important Details – Please read prior to installation

**Ensure the AC/Mains power is NOT connected and cannot be unexpectedly reconnected during installation.**

1. This product must be installed by a qualified electrician in accordance with instructions provided and in compliance with recognised electrical and safety regulations relevant to the country it is being installed.
2. This product is suitable for installation on surfaces with normal flammability e.g. wood, masonry. It is not suitable for use on highly flammable surfaces or in flammable atmosphere.
3. This product must be securely fixed to the mounting surface using the fixings clips, screws and wall plugs supplied. The screws and wall plugs are suitable for "masonry" only. Other fixings are not supplied and must be purchased.
4. Please use the cable gland supplied in the box if the LED batten is required to be linked.
5. Connect the power lead to a suitable junction box to maintained IP rating. Please pay attention to the polarity as shown in (Fig.2) and to the illustration below.
6. Recommended cable H05RN-F 3x1.00mm<sup>2</sup>.
7. Please use the protective cover on any unused connector.
8. Maximum no of units in series is 20 using recommended cable.
9. This product is not suitable for dimming.

**IMPORTANT! This product is a Class II device. However an earth connection is required.**

### Installation Instructions

1. Ensure the Locking Nut, Cover and Seal have been placed on the wire in that order (Fig.1).
2. Insert the Live, Neutral and Earth wires into the corresponding ports on the connector block and tighten screws (Fig.2).
3. Slide the Seal over the connector block, ensuring the push-fit connection clicks into place (Fig.3).
4. Slide the cover into place over the Connector Block, then screw the Locking Nut into place and tighten to seal the connection (Fig.4).
5. Connect the female connector the male connector on the batten. Slide the Cover over the connection and screw tightly into place (Fig.5).

### Linking multiple battens

To link multiple battens together, install a connection assembly on either end of a length of cable (Fig.13). Use this to create a connection between two cables (Fig.14). Repeat for as many battens as you would like to link together (maximum 20 battens from one mains power connection).

### Warranty

This unit carries a 3 year warranty from the date of purchase, providing that it has been installed correctly and not modified in any way. Should a fault occur please contact the original place of purchase.

### Important Notes

- Operating and storage of luminaire must be within rated temperature and humidity guidelines. Operation must be within rated input voltage.
- Keep away from strong electromagnetic radiation sources and protect from lightning strike.

- Should the unit malfunction, return to distributor or reseller. No user serviceable parts inside. Risk of electric shock, do not disassemble or attempt to repair the luminaire.
- Do not install or use the luminaire if the casing is found to be broken.
- The luminaire must be installed by a qualified electrician.
- The luminaire should be positioned away from heat and vibration. Avoid contact with any corrosive chemicals.
- The luminaire should be mounted in free air it is recommended not to exceed 30°C ambient.
- Never cover the luminaire with heat insulation materials.
- The luminaire should be positioned at least 1 metre away from radios devices, failure to do so may affect radio reception.

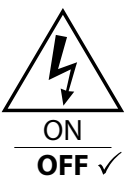
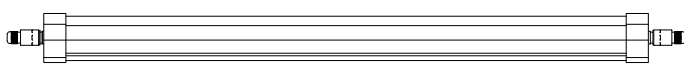
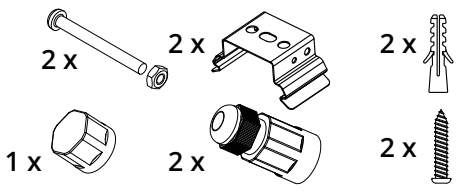
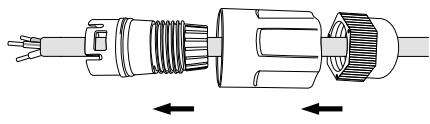
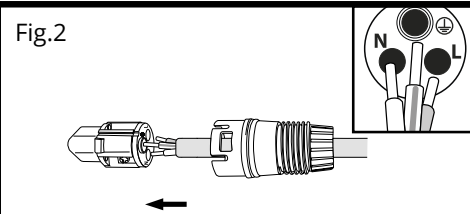
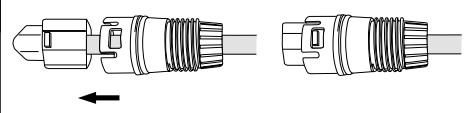
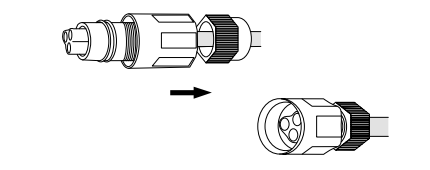
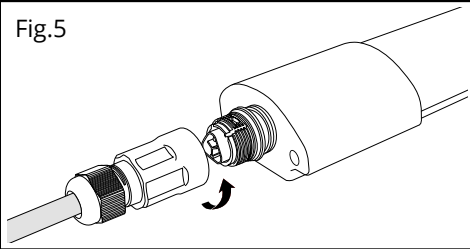
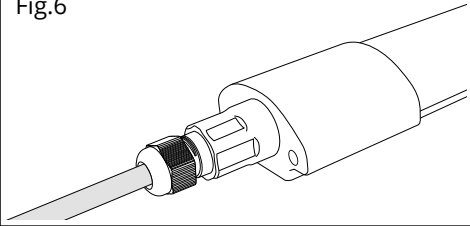
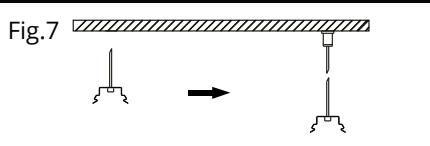
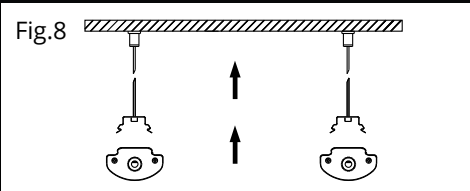
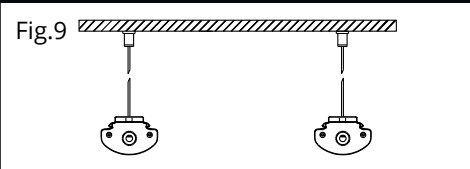
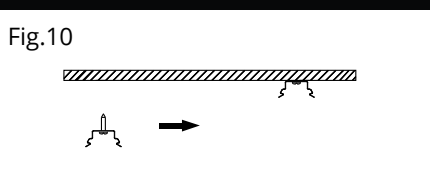
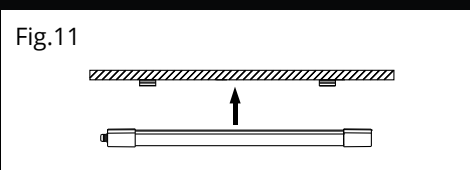
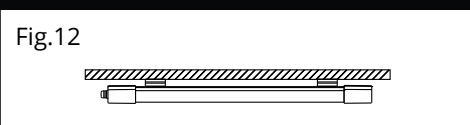
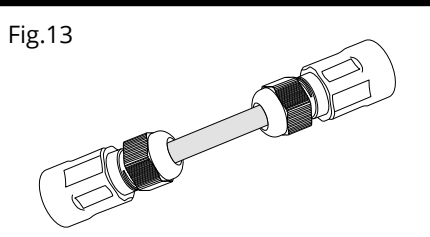
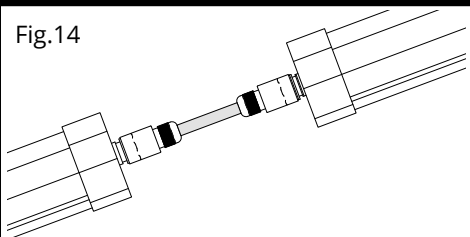
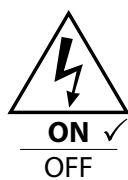
Installation		
		
Fig.1	Fig.2	Fig.3
		
Fig.4	Fig.5	Fig.6
		
Suspended*		
Fig.7	Fig.8	Fig.9
		
Surface mount		
Fig.10	Fig.11	Fig.12
		
Fig.13	Fig.14	
		

\* Requires suspension kit ILBASK091 supplied separately