

INSTALLATION INSTRUCTION

for Integral DiffusaLITE LED Wide Batten Range

(Standard, Sensor, Emergency & Multi Power & CCT options) - 5 Year Warranty

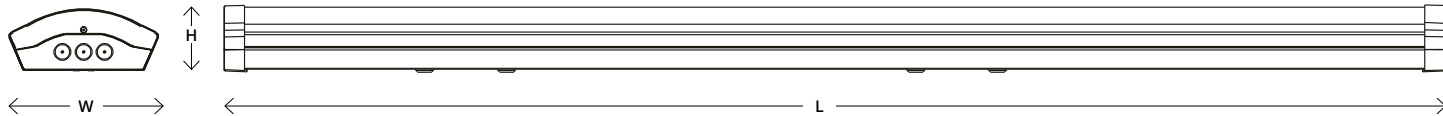

LED Batten Model	Description 200811790	Lumens	Product Dimensions (mm) (LxWxH)	Net Weight (Kg)
ILBTK101	4ft 20W 4000K Non-Dimmable	2500	1190x200x81	2.1
ILBTK102	5ft 30W 4000K Non-Dimmable	3750	1490x200x81	2.6
ILBTK103	6ft 40W 4000K Non-Dimmable	5000	1790x200x81	3.1
ILBTK104	4ft EM3HR 20W 4000K Non-Dimmable	2500	1190x200x81	2.3
ILBTK105	5ft EM3HR 30W 4000K Non-Dimmable	3750	1490x200x81	2.8
ILBTK106	6ft EM3HR 40W 4000K Non-Dimmable	5000	1790x200x81	3.3
ILBTK121	4ft 38W 4000K Non-Dimmable	4750	1190x200x81	2.1
ILBTK122	5ft 58W 4000K Non-Dimmable	7250	1490x200x81	2.6
ILBTK123	6ft 65W 4000K Non-Dimmable	8125	1790x200x81	3.1
ILBTK124	4ft EM3HR 38W 4000K Non-Dimmable	4750	1190x200x81	2.3
ILBTK125	5ft EM3HR 58W 4000K Non-Dimmable	7250	1490x200x81	2.8
ILBTK126	6ft EM3HR 65W 4000K Non-Dimmable	8125	1790x200x81	3.3
ILBTK128	5ft 58W MW 4000K Non-Dimmable	7250	1490x200x81	2.7
ILBTK131	5ft EM3HR MW 58W 4000K Non-Dimmable	7250	1490x200x81	2.9
ILBTK142	5ft 30W/58W 3000K/4000K/6000K Non-Dimmable	3750/7250	1490x200x81	2.6
ILBTK145	5ft EM3HR 30W/58W 3000K/4000K/6000K Non-Dimmable	3750/7250	1490x200x81	2.6
ILBTK148	5ft 58W 3000K/4000K/6000K DALI-Dimmable	7250	1490x200x81	2.6
ILBTK151	5ft EM3HR 58W 3000K/4000K/6000K DALI-Dimmable	7250	1490x200x81	2.6

Thank you for purchasing and Integral LED product. When installed correctly this unit will provide years of service with no lamp changes required. For support or warranty information please visit www.integral-led.com/warranty. Always turn off power at the distribution unit before any maintenance or installation. Please ensure the power cannot be re-connected inadvertently.

Important Details – Please read prior to installation

Ensure the AC/Mains power is NOT connected and cannot be unexpectedly reconnected during installation.

General guidelines for installation:

1. This luminaire must be installed by a qualified electrician in accordance with the instructions provided and in compliance with recognised electrical and safety regulations relevant to the country it is being installed.
2. This is a Class I luminaire. Earth connection is required.
3. The input voltage of this luminaire is 200-240V~ 50/60Hz.
4. This luminaire is suitable for surface, pendant, conduit and BESA box mountings. Adequate for installation on surfaces with normal flammability e.g. wood, masonry. Before making the fixing hole(s), check that there are no obstructions hidden beneath the mounting surface, such as pipes or cables. It is not suitable for use on highly flammable surfaces or in flammable atmosphere.
5. This luminaire is **not suitable for dimming** with the exception of ILBTK148 & ILBTK151 which are DALI compatible.
6. No user serviceable parts.
7. Ensure mains supply is isolated before starting any work.
8. Operating Temperature -20°C to +45°C. Do not exceed.
9. Keep away from strong electromagnetic radiation sources.

10. Should the unit malfunction, return to distributor or reseller. No user serviceable parts inside. Do not disassemble or attempt to repair the luminaire outside of the installation guidelines.
11. Do not install or use the luminaire if the housing/diffuser is found to be broken.

Emergency Operation

The emergency option can be operated in maintained or non-maintained mode.

1. The luminaire delivers 360 lumens in Emergency mode.
2. Ensure the emergency battery is connected to the connector on the emergency driver.

For maintained operation:

- Connect the Live cable (Brown) to terminal (PL).
- Connect the Switch Live cable to terminal (SL).

For non-maintained operation:

- Connect the Live cable (Brown) to terminal (PL).
 - Leave terminal (SL) disconnected.
3. When powered on, the green LED indicator will illuminate indicating that the battery is being charged.
 4. To check that the emergency function is working, press the red test button at any time and the batten should illuminate in emergency mode.
 5. On failure of the permanent mains supply the fitting will switch automatically from battery charging to battery discharge powering the LED batten.
 6. This luminaire is designed to provide 3hrs of emergency light following a power failure. Please allow a full 24 hour charge before carrying a 3 hour test and mark the installation date on the LED batten label.
 7. This luminaire contains a battery. For replacement please contact Integral-LED.com
 8. Please find Testing Schedule log at the end of this installation guide.

Warranty

This unit carries a five year warranty from date of purchase, providing it has been installed correctly and not modified in any way. Should a fault occur please contact the original point of purchase.

Important Notes

1. The luminaire must be operated within the temperature range defined and avoiding extreme humidity.
2. Operation must be within rated voltage.
3. Keep away from strong electromagnetic radiation sources and protect from lightning strike.
4. Should the unit malfunction, please return it to the distributor or reseller, never attempt repair yourself.
5. Do not install the luminaire if any part is broken. Do not apply direct pressure to the front
6. The luminaire must be installed by a qualified electrician.
7. The luminaire should be positioned away from heat, liquid and vibration. Ensure no contact with any corrosive chemicals.
8. The luminaire should be mounted in free air and operated at an ambient temperature of 30° degrees.
9. Never cover the luminaire with any covers or insulation materials.
10. The luminaire should be positioned at least 1m away from radios as this may affect the signal reception. IP20 rated protection.

Settings

Detections area, hold time and daylight sensor can be set by using DIP switches on the sensor. Note that reducing the detection area will also reduce the sensitivity.

I. Detection area

- Up to 100%
- Up to 75%
- Up to 50%
- Up to 25%
- Up to 10%

		1	2	3	
ON ↑ [Switch Icon]	I	ON	ON	ON	100%
	II	-	ON	ON	75%
	III	ON	-	ON	50%
	IV	-	-	ON	25%
	V	-	-	-	10%

II. Hold time

Refers to the time period the lamp remains at 100% illumination after no motion is detected.

- Up to 100%
- Up to 75%
- Up to 50%
- Up to 25%
- Up to 10%

		4	5	6	
ON ↑ [Switch Icon]	I	ON	ON	ON	5s
	II	-	ON	ON	30s
	III	ON	-	ON	90s
	IV	-	-	ON	3min
	V	ON	ON	-	20min
	VI	-	-	-	30min

III. Daylight sensor

The sensor can be set to only allow the lamp to illuminate below a defined ambient brightness threshold. The settings are as follows:

- 2lux, darkness operation only
- 10lux, darkness operation only
- 25lux, twilight operation
- 50lux, twilight operation
- Disable

		7	8	9	
ON ↑ [Switch Icon]	I	ON	ON	ON	2lux
	II	ON	ON	-	10lux
	III	ON	ON	-	25lux
	IV	ON	-	-	50lux
	V	-	-	-	Disable

Specifications

Operating voltage	220~240Vac, 50Hz
Rated load	400W (inductive), 800W (resistive)
HF system	5.8GHz±75MHz, ISM wave band
Transmitting power	<0.5mW
Power consumption	≤0.5W (standby)
Detection zone	Max. (D x H): 12m x 6m
Detection sensitivity	10% / 25% / 50% / 75% / 100%
Hold time	5s / 30s / 90s / 3min / 20min / 30min
Daylight sensor	2lux / 10lux / 25lux / 50lux / Disable
Mounting height	6m Max.
Motion detection	0.5~3m/s
Detection angle	150° (wall installation) 360° (ceiling installation)
Operating temperature	-20~60° C
IP rating	IP20

Detection Pattern

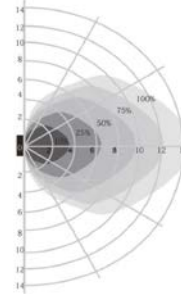

Wall mounting pattern (Unit: m)
Suggested installation height: 1.5m

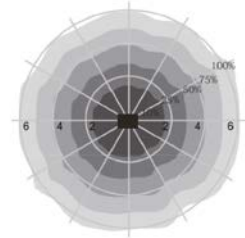

Ceiling mounting pattern (Unit: m)
Suggested installation height: 3m

*When set to Disable, the daylight sensor will switch on the lamp when motion is detected regardless of ambient light levels.

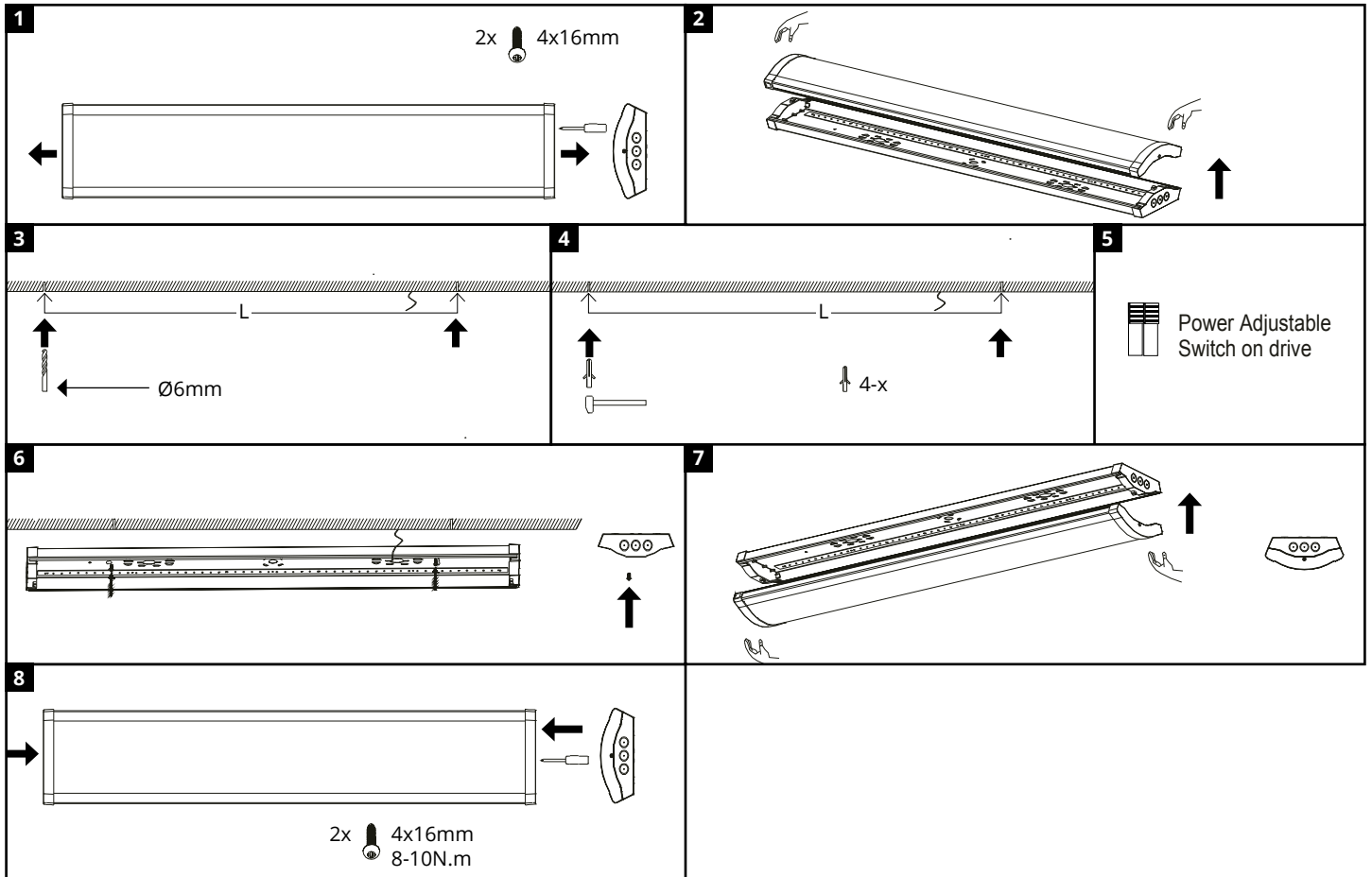

Test Schedule to record monthly functional test and yearly 3 hour duration test for emergency version. All testing should be planned and incorporated as part of a managed programme with appropriate risk assessment to ensure operational emergency function is not compromised during testing.

Panel Ref/Location 	In case of difficulty, contact the Installation Engineers: tel.					
Full Recharge Time 24 Hours			Duration 3 Hours			
TEST RECORD						
	Year 1		Year 2		Year 3	
Monthly Test	Signed	Date	Signed	Date	Signed	Date
Functional						
Functional						
Functional						
Functional						
Functional						
Functional						
Functional						
Functional						
Functional						
Functional						
Functional						
Functional						
Functional						
Three Hour						

