

integral™ LED

INSTALLATION INSTRUCTIONS
INSTRUCTIONS D'INSTALLATION
INSTALLATIE INSTRUCTIES
INSTRUCCIONES DE INSTALACIÓN
INSTALLATIONSANLEITUNG
INSTRUKCJE INSTALACJI
INSTRUÇÕES DE INSTALAÇÃO

SLIM ECO IP65 BATTEN



IS 1001



This product contains a light source of energy efficiency class <E>

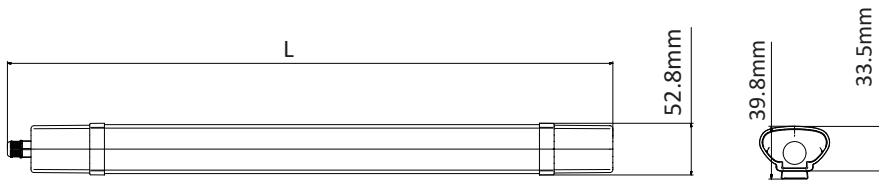

ILBTE101 L=618mm ILBTE102 L=1218mm ILBTE103 L=1518mm

1

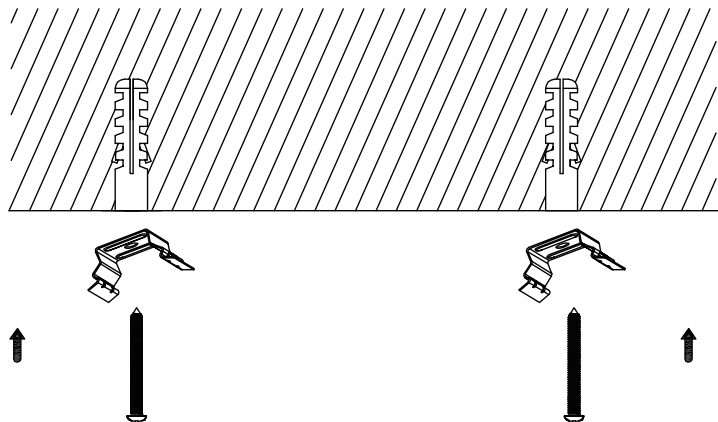

2

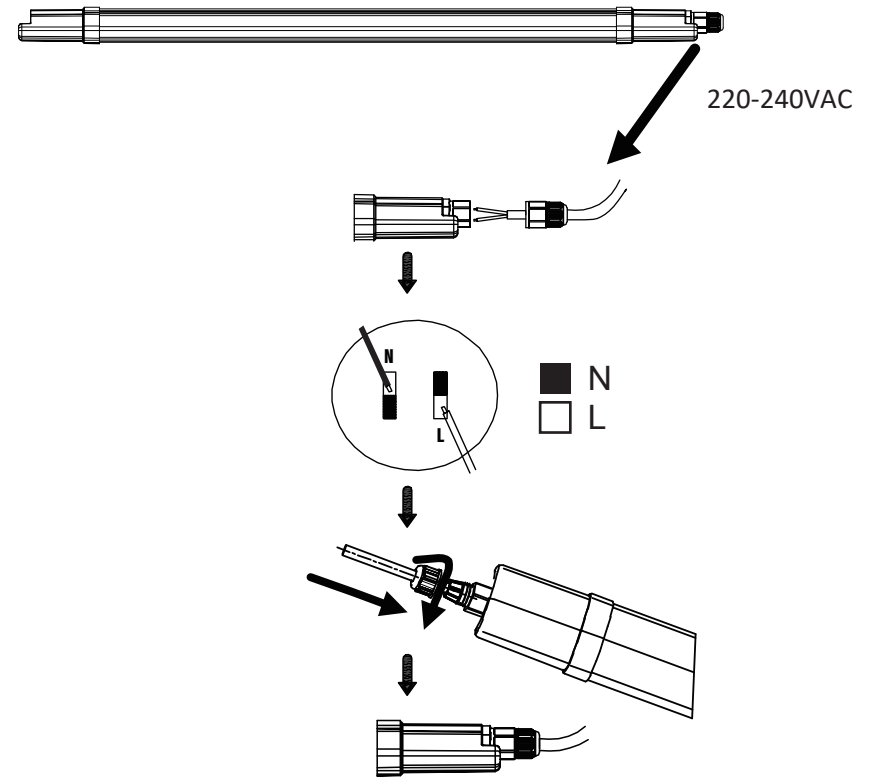

3

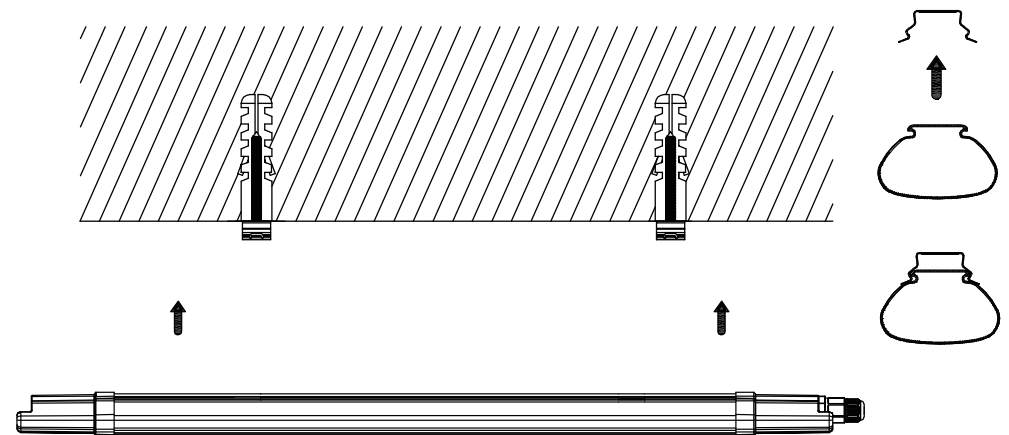

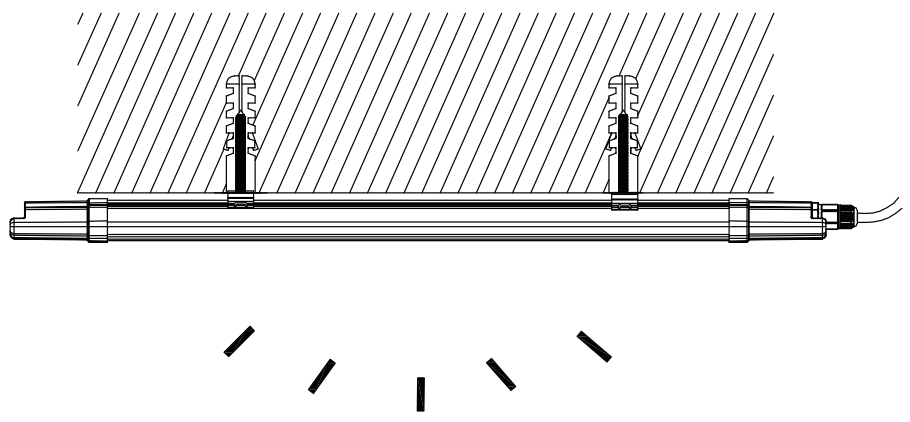
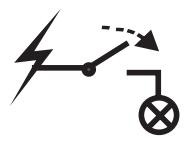

Warranty/ Technical & contact information are all available at www.integral-led.com

IS1051 A



Integral LED is a division of Integral Memory plc:
Unit 6, Iron Bridge Close, Iron Bridge Business Park,
London, NW10 0UF, UK
Integral Europe BV, 2801 DG, NL