



## INSTALLATION INSTRUCTION

### ILSENMW003 MICROWAVE SENSOR FOR RECESS MOUNT

#### 3 Year Warranty



Thank you for purchasing an INTEGRAL LED product. When installed correctly this unit will provide years of service - with no replacements required. For support or warranty information please see [integral-led.com](http://integral-led.com). Always turn off circuit power at the distribution unit before installation and maintenance. Please ensure that the power cannot be connected inadvertently.

#### Important Details – Please read prior to installation

- This sensor must be installed by a qualified electrician in accordance with the instructions provided and in compliance with recognised electrical and safety regulations relevant to the country it is being installed.
- This is a Class II sensor. Earth connection is not required.
- The input voltage of this sensor is 200-240V~ 50/60Hz
- This sensor is only suitable for recess mount. Adequate for installation on surfaces with normal flammability e.g. wood, masonry. Before making the fixing hole(s), check that there are no obstructions hidden beneath the mounting surface, such as pipes or cables. Do not use on highly flammable surfaces or in flammable atmosphere.
- This sensor is designed to be installed in a ceiling tile/solid material, with a minimum thickness of 3mm.
- This product is for Indoor use only. It should not be covered with insulation material at any time.
- This product is not suitable for dimming.
- Ensure mains supply is isolated before starting any work.
- Operating Temperature: -20°C to +40°C. Do not exceed.
- Should the unit malfunction, return to distributor or reseller. No user serviceable parts inside. Do not disassemble or attempt to repair the sensor outside of the installation guidelines.
- Do not install or use the sensor if the housing is found to be broken.

#### Installation Instructions

- Ensure the AC/mains power is not connected and cannot be reconnected during installation.
- For new installations use cutting tools suitable for the material and carefully cut the required hole to allow installation.
- For Refurbishment installations ensure that the existing hole is suitable and strong enough to hold the new sensor. Support the surrounding area if required.
- Remove the transparent terminal cover, unscrew the connection terminals and connect the Mains power and the Load wires according to the wiring diagram (See Fig.1 and Fig.2).
- Re-install the transparent terminal cover, switch on the Mains power supply and test.
- Once tested and in good working order, raise the springs, place the sensor into the cut-out ensuring that no power cables are trapped and position fully into the aperture until sensor is flush to the surface

#### SPECIFICATION:

Mains Input: 220 -240V/AC, 50/60Hz

Ambient Light: <10-2000LUX (adjustable)

Time Delay: Min.10sec±3sec

Max.15min±3 min

Rated Load: 1200W 

300W 

Detection Range: 360°

Detection Distance: 3-10m (radius, adjustable)

Frequency: 5.8GHz, ISM band

Power Consumption: approx. 0.9W

Installation Height: 1.5-3.5m

Detection Motion Speed: 0.6-1.5m/s

## TEST PROCEDURE:

1. Turn the TIME knob anti-clockwise to the minimum (10s). Turn the SENS knob clockwise to the maximum (+). Turn the LUX knob clockwise to the maximum (SUN). ☀
1. Switch on the power and allow 30sec for sensor to warm up, during which time sensor and its connected load will remain off. After 30sec, the sensor will turn on the load upon induction signal received (motion detected). If no further motion is registered, the load should switch off within  $10\text{sec} \pm 3\text{sec}$ .
1. Turn LUX knob anti-clockwise to the minimum (MOON) 🌙. If the ambient light is more than 10LUX, the sensor and load will not operate. If the ambient light is less than 10LUX (darkness), the sensor will resume motion detection and switch connected load on. Under no induction signal condition, the load should switch off within  $10\text{sec} \pm 3\text{sec}$ .

**Note: When testing in daylight, please turn LUX knob to ☀ (SUN) position, otherwise the sensor will automatically switch off!**

## TROUBLESHOOTING:

### The load doesn't work:

- a. Check the Mains power and the load connections.
- b. Indicator light turns on after sensing motion, but load is off - Please inspect load.
- c. The indicator light is not on after sensing, please check if the daylight threshold setting on the dial corresponds to the ambient light.
- d. Please check if the working voltage corresponds to the power source

### The sensitivity is poor:

- a. Please check the ambient temperature.
- b. Please check for obstructions in front of the sensor, affecting the signal reception.
- c. Please check if the signal source is in the detection field.
- d. Please check the installation height.

### The sensor doesn't switch the load off:

- a. Check for continual signals in the detection field.
- b. Check if time delay isn't set to the longest, adjust setting accordingly.
- c. Ensure the power connections correspond to the wiring instructions.

## Installation Diagram

Fig. 1

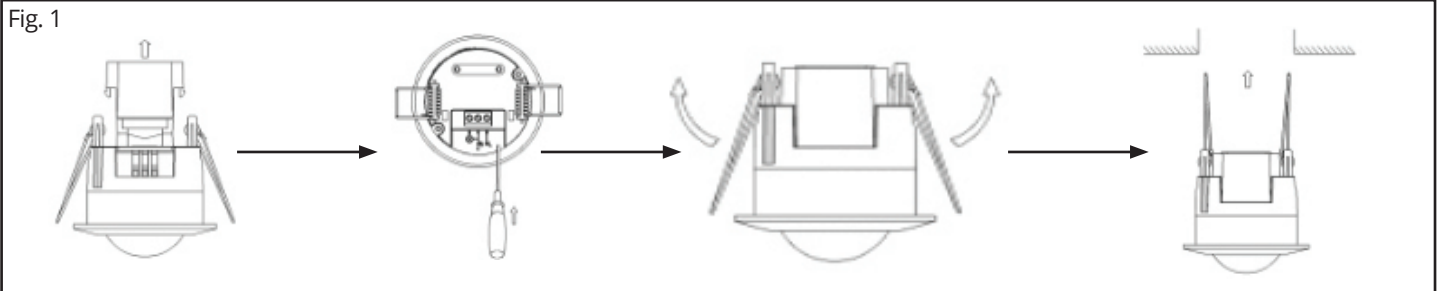

Fig. 2

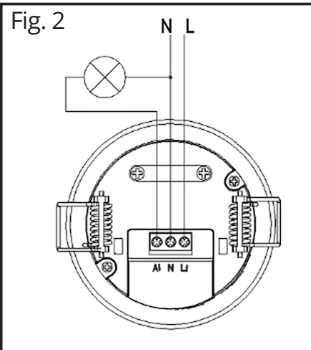

Fig. 3

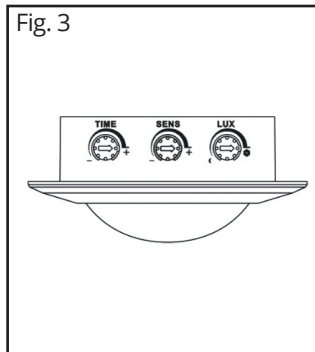

Fig. 4

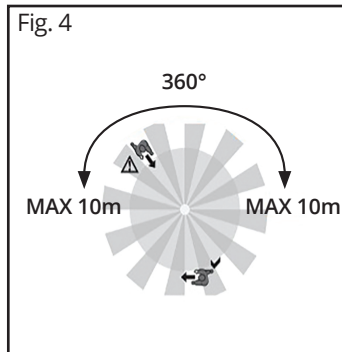
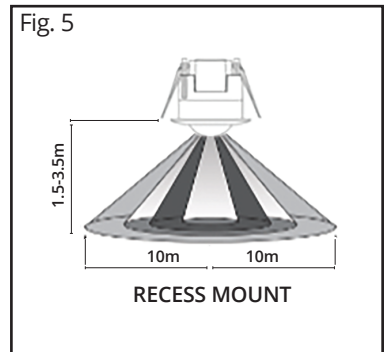

Fig. 5



Warranty/Technical and contact information are all available at [www.integral-led.com](http://www.integral-led.com)

Integral LED is a division of Integral Memory plc, Unit 6 Iron Bridge Close, Iron Bridge Business Park, London, NW10 0UF, UK